

R-44 4-CHANNEL PORTABLE RECORDER

Specifications

| | | | |
|--|--|--|---|
| Recorder Section | | Recommended Load Impedance | Line : 4k ohms or greater Headphone : 16 ohms or greater |
| Channels | 4 | Output Level | Line Output : -20 dBu (fixed) Headphone : 40 mW + 40 mW |
| Data Type | Format : WAV/BWF | Total Harmonic Distortion + Noise | Line Output : 0.02 % (Input Sens : +4 dBu) |
| Sampling Bit Rate | 16/24-bit | Noise Level | Line Output : -100 dBu (Input Sens : +4 dBu, Input Level : Center) |
| Sampling Frequency | 44.1kHz/48kHz/88.2kHz/96kHz/192kHz * 16 or 24-bit sampling rate can be selected with any frequency | Residual Noise Level | Line Output : -103 dBu (Input Sens : +4 dBu, Input Level : Minimum) |
| Recording Media | SDHC memory card (compatible with 64 MB - 8 GB*) * As of November 2007. | Frequency Response | 20Hz - 40kHz(0/-3 dB) |
| Recording Time using 8 GB SDHC card | 16 bit/44.1kHz | 16 bit/48kHz | 24 bit/48kHz |
| | 24 bit/96kHz | 24 bit/192kHz | |
| | Stereo | 755 minutes | 694 minutes |
| 4 ch | 377 minutes | 347 minutes | 231 minutes |
| | | | 115 minutes |
| * Recording times are approximate. Actual results may vary somewhat. * If more than one recorded file exists, the total recordable time will be less than listed. | | | |
| Input and Output | | Dynamic Range | AD : 100 dB DA : 104 dB |
| Analog Input | Ch 1 - 4 : XLR/TRS Combo type, XLR type (phantom powered), TRS type (balanced/unbalanced), Stereo Built-in Microphones | Phantom Power | 48 V + or - 4 V, 8 mA per 1 channel (20 mA or less in all channels) |
| Analog Output | Ch 1 - 4 : RCA Pin type (line output) Headphone : Stereo Phone type (1/4 inch) | Other Terminals | |
| Digital In/Out | RCA Pin type (IEC 60958-3) | USB Port | Mini-B Type Connector USB 1.1 or 2.0 High Speed (Mass Storage Class) |
| Input Impedance | XLR: 4k ohms or greater (balanced), TRS: 6k ohms or greater (balanced) | Control Sync Jack | Stereo Mini Type Jack Word clock sync and start/stop remote control of 2 units * Remote control function does not guarantee the exact same REC start time |
| Nominal Input Level | 11 steps : -56, -50, -44, -38, -32, -26, -20, -14, -8, -2, +4 (Input Level Knob : Center) | Others | |
| Maximum Input | +24 dBu (Input Sens Knob: +4 dBu) | Display | 128 x 64 dot organic LED |
| Output Impedance | Line Output : 600 ohms | Power Supply | AC adaptor (PSB-1U), AA type battery x 4 (Alkaline or NiMH) |
| | | Current Draw | 1.2 A |
| | | Dimensions | 157(W) x 183(D) x 61(H) mm (6-3/16(W) x 7-1/4(D) x 2-7/16(H) inches) |
| | | Weight | 1.3 kg (2 lbs 14 oz) including batteries |

* 0 dBu = 0.775 Vrms

System Requirements Microsoft® Windows® Vista®/XP/2000, Mac OS X 10.2 or later

Block Diagram

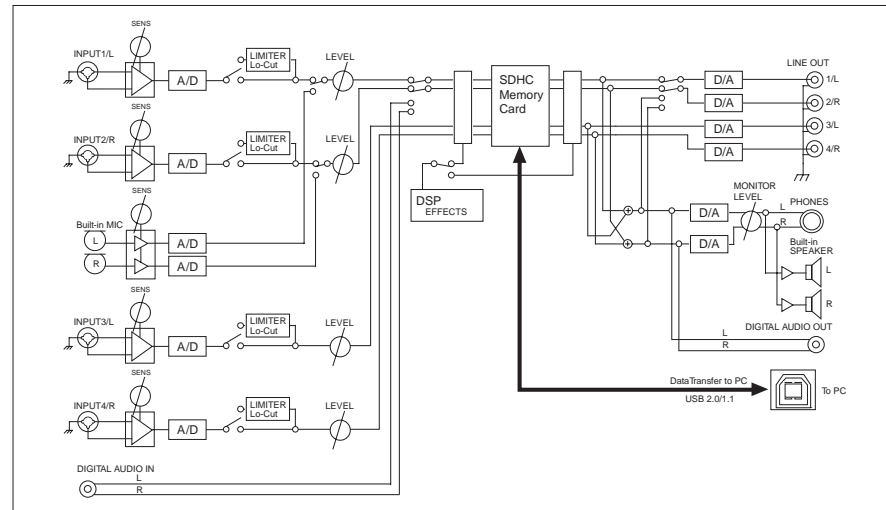

Dimensions

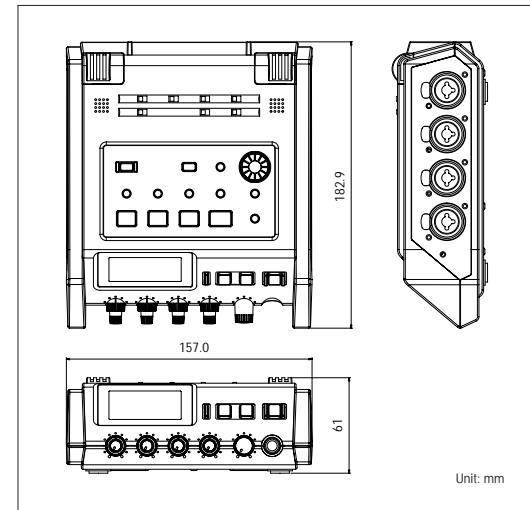

Optional Items

CB-R44 Carrying Bag

Dedicated carrying bag with shoulder strap for safe, comfortable use in the field.



CS-50 Stereo Shotgun Microphone

Stereo condenser type microphone for stereo recording.



RH-200 Monitor Headphones

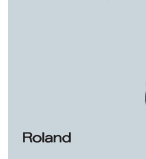

RH-300 Monitor Headphones



Related Items

R-4 4-Channel Portable Recorder and Wave Editor

The R-4 with built-in 40GB HDD is a great companion for many DV and HDV cameras not equipped with time code. The L-control connector allows the R-4 to record, pause and stop via the camera controls.



R-4 Pro 4-Channel Portable Recorder with SMPTE Timecode

The R-4 Pro with built-in 80GB HDD shares the R-4's rugged construction and robust feature set. The R-4 Pro also includes AES/EBU digital input/output and SMPTE time code to work with professional video cameras or decks.



● All specifications and appearances are subject to change without notice. ● SDHC Logo is a trademark. ● Microsoft and Windows are registered trademarks of Microsoft Corporation. Windows® is known officially as : "Microsoft® Windows® operating system." Windows Vista is a registered trademark of Microsoft Corporation. ● Mac OS is a trademark of Apple Computer, Inc. ● Fugue© 2008 Kyoto Software Research, Inc All rights reserved. ● All product names mentioned in this document are trademarks or registered trademarks of their respective owners.



Compact and light-weight 4-channel audio field recorder. Professional quality recordings with sampling rates up to 24-bit/192kHz.

Uncompressed
24-bit/192kHz
linear PCM

Light-weight
1.3kg
compact body

Supports
SDHC
large capacity media

AA batteries for
4 hours
of recording



A compact, solid state, four channel field recorder.



- Built-in mics**
Stereo microphones. Input sensitivity knob and high response meter enable precise level adjustment.
- Phantom Power Switches**
On/Off switch to control the phantom power supply to XLR input jacks. Independent control of each input.
- Hold Switch**
Prevents unintentional operations by locking the top and front panel buttons.
- Exit Button**
Returns to previous screen or cancels current operation.
- Effects Button**
Calls up on-board studio class effects. Assign to inputs and outputs as well as individual channels.
- Marker/Cursor Buttons**
Pressing the MARK button adds markers to the project enabling quick access to points of playback. The 4 buttons also work as cursor control while a menu is selected.
- A-B Repeat Button**
Set A-B points in a project to repeat playback between loop points.
- Built-in speakers**
Speakers for stand-alone monitoring.
- Limiter Switch**
Suppresses sudden audio peaks and compresses signal to a threshold level. Independent On/Off or stereo link of channels 1-2 and 3-4 is possible.
- Low-Cut Switch**
Rolls off low frequencies within input signals to prevent noise such as mic handling, breath pops or wind noise.
- Scrub Dial**
Enables speedy selection of parameters or changing values within menus. Moves current position forward or backward during playback or pause.
- Menu Button**
Calls up menu screen for REC/PLAY setup or other system preferences.
- ENTER/FINDER Button**
Use to set a value or parameter selection. This also calls up the Finder function allowing file management functions such as Delete, Copy, Move, etc.
- PREV/NEXT/PLAY Buttons**
PREV and NEXT buttons allow selection of the previous or next file. Hold down these buttons for rewind or fast-forward. PLAY button lights in blue during playback.
- Display**
Organic LED provides high contrast and quick response with benefits of wide angle visibility.
- Input Sensitivity & Level Knobs**
Dual type knobs adjusts both input sensitivities and levels for Ch 1-4 independently.
- Display Button**
Switches current contents to be shown on display.
- STOP/PAUSE/REC Buttons**
REC button lights in red during recording and blinks in standby mode. The slanted panel provides smooth and easy access.
- Phone Jack & Level knob**
1/4 inch stereo phone jack for headphone connection and level adjustment knob.

- Memory Card Slot**
For SD and large capacity SDHC cards.
- USB Port**
Mini B type port for computer connection. Enables copying files to or from computers.
- Control Sync**
Link two R-44 units together for 8-channel recording.
- Combo Type Input Terminals**
Support both balanced (XLR/TRS type) and unbalanced (standard type) inputs. Phantom power can be supplied to each XLR jack.

- Digital Output**
Digital coaxial type connector for output to external digital devices such as speakers/mixers.
- Line Output Terminals**
Four RCA jacks for independent monitoring of all channels.
- Digital Input**
Digital coaxial type connector for inputting digital signals.

R-44 4-CHANNEL PORTABLE RECORDER

USB 2.0 Windows Vista®/Windows®XP/2000 Mac OS X

* SD Memory Card and Batteries are not included.

Pro quality four channels recordings to large capacity SDHC cards.

The Edirol R-44 is designed for professional use within a very conveniently sized package. Capture up to 4 channels of uncompressed audio with selectable bit depths (16-bit or 24-bit) and sampling frequencies (44.1kHz/48kHz/88.2kHz/96kHz). R-44 employs SD cards or large capacity SDHC cards as the recording media. No moving parts enables the most silent and reliable operation possible.



Built-in stereo microphones and monitor speakers.

Although the R-44 is compact, all the necessary functions are included. Built-in high quality microphones and speakers make recording and monitoring without external devices possible.

Built-in limiter, low-cut filter and studio class effects.

An on-board limiter helps suppress sudden peaks in sound from an input source. A low-cut filter is included to help prevent things like wind noise or mic handling noise. Studio class effects such as 3-Band EQ, 6-Band GEQ, Enhancer or DeEsser can be used as tools to greatly improve audio quality. Effects can be applied while recording or simply for monitoring/playback.

| Built-In Effects | |
|---------------------------|--|
| 3-Band EQ | 3-band parametric EQ; allows precise equalization with high/low shelving and peaking |
| 6-Band Graphic EQ | 6 point frequency band equalization; ideal for recording |
| Noise Gate | Minimizes noise during low audio levels, cuts low frequency noise |
| Enhancer | Clearly defines and enhances sound; good for dialogue |
| Comp & DeEsser | Cuts hissing, smoothens the sound, makes audio level uniform |
| MS Mic Mixing | Generates stereo mix with specified spread from inputs of Mid-Side Microphones |

* Effects can be applied on both input and output
* Effects are not available while sample rate is set to 192kHz

Pre-Record function ensures you never miss that important moment again.

The Pre-Record function buffers input signals for a certain amount of time. When the REC button is pressed, the material from the previous few seconds (selectable) is included. This also helps reduce sound bites at the beginning of a recording by not having to start the recorder too early.

Combo type analog jacks and digital output enables connection with a variety of devices.

The combo input jacks (4) supports the connection of both XLR and 1/4 inch plugs. XLR inputs are equipped with phantom power. Eleven steps of input sensitivity enable the connection of various devices with a variety of inputs levels



from microphones to musical instruments. High quality analog circuitry in the preamp ensures superior recording results.

High-contrast Organic LED display and operation-oriented user interface.

The high contrast, high response organic LED screen, viewable from wide angles ensures fluid operation in field recording situations. The high response of level meters makes precise level adjustments possible. All the necessary switches and knobs are located on the top and front panels. Self-lit buttons on all the key controls enable clear-cut recording operations.

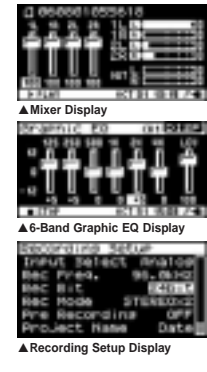

Capture eight channels by linking two units.

The Control Sync terminal enables synchronized operation of 2 units. Control the second unit from the master by simply connecting two with a stereo mini cable. The master unit can remotely control REC standby, REC start and REC stop of the slave unit. This function enables 8-channel recording in a compact space and at an affordable price.



Link to computer via high speed USB.

The R-44 can be mounted on computers with a simple USB 2.0 connection. It is seen as an USB

storage device on a computer. You can copy data back and forth with a simple drag & drop operation.



Four hours of recording with four AA batteries.

The R-44 can be operated with 3 types of power supply, AC adaptor, external battery and AA batteries. Four hours* of operation is possible with NiMH or alkaline batteries.



* at 16-bit/44.1kHz stereo. No phantom power and pre-record disabled.